

CES SERIES WATER SOFTENERS

INSTALLATION, OPERATION AND MAINTENANCE GUIDE

2900E SINGLE 2900E DUPLEX PARALLEL
 2850E SINGLE 9500E TWIN

INTRODUCTION

Everpure from Pentair Water Solutions CES Series water softeners are designed to enhance water quality for commercial use. Reducing hard minerals helps lower maintenance needs, prolongs equipment life, and ensures consistent product performance. Routine maintenance is key for dependable, long-term operation.

NOTES

Do not discard. Give this guide to the owner/operator after installation.

- This installation manual contains important information related to the installation, startup and operation of the Pentair Everpure 2850E, 9500E, 2900E, and 2900E-DP Series water softeners. In addition to this document, a Control Valve Manual and Programming Guide ("E" Series models) have been provided. The Control Valve Manual covers general operating information, in addition to detailed exploded parts views of the control valve, valve drive and brine system.
- The Programming Guide (only "E" Series models) includes step-by-step procedures for programming the controller for your specific application.
- Many sections of this manual will apply to all models, whereas some sections may be more series specific. Specific model differences will be highlighted. Refer to the general arrangement drawings for examples of typical plumbing configurations and identification of various components and their connection points.

OPERATIONAL SPECIFICATIONS

For use on cold water only.

Pressure Requirements:

An operating water pressure between 25 and 125 PSI (1.7 - 8.6 bar).

Note: When daytime water pressure exceeds 80 psi (5.5 bar), the maximum pressure rating of 125 psi (8.6 bar) can be exceeded. A pressure regulator must be installed on this system or warranty is voided.

If pressure is greater, install a pressure regulating valve ahead of the system. If water pressure is lower, install additional equipment to maintain a 30 PSI (2.1 bar) minimum operating pressure.

Temperature: 40-100°F (4-38°C)

1. Clear (non-turbid) water supplies (less than 5 NTU).

CAUTION The pressure vessels (mineral tanks) provided with the system should be protected from the following conditions:

- a. Vacuum in excess of 5 ½" Hg (17 Pa) below atmospheric - If negative pressure should ever exceed 5 ½" Hg (17 Pa), an adequate vacuum breaker must also be properly installed. A vacuum breaker should be installed just prior to the inlet of the control valve. Systems utilizing multiple controls will require a vacuum breaker for each control valve.

Improper installation of a vacuum breaker when required, may void the mineral tank warranty.

Vacuum Breaker Installation

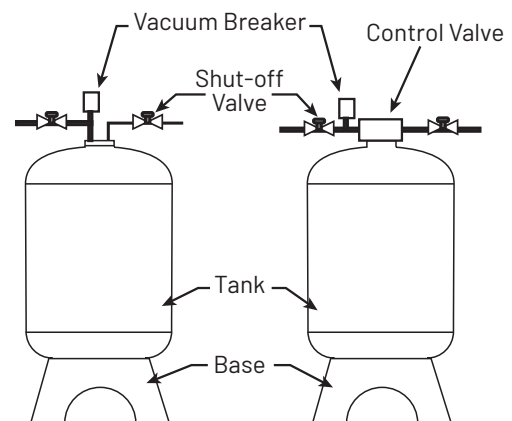

PERFORMANCE SPECIFICATIONS

Series	Model	Exchange Capacity per Tank						Resin Volume per Tank (cubic foot)	Service Flow Rate		Drain Flow		Drain Line		Resin Tank Size (in.)	Brine Tank		Ship Weight (lbs.)	Operating Weight (lbs.)	
		Maximum		Medium		Minimum			Rated (gpm) 15 psi Pressure Drop	Intermittent (gpm) 25 psi Pressure Drop	Maximum (gpm)	Volume - Max (gal.)	Connection Size (in.)	Min. Diameter (in.)		Size (in.)	Salt Capacity (lbs.)			
		Kilograms	Pounds Salt	Kilograms	Pounds Salt	Kilograms	Pounds Salt													
2850E Single	CES-2850E-75	75	37.5	62.5	22.5	50	15	2.5	27	35	3.5	125	1.5	0.75	0.75	13 x 54	18 x 40	425	225	885
	CES-2850E-90	90	45	75	27	60	18	3	32	42	5.0	162	1.5	0.75	0.75	14 x 65	24 x 40	750	290	1,420
	CES-2850E-120	120	60	100	36	80	24	4	34	44	7.0	198	1.5	0.75	0.75	16 x 65	24 x 40	750	360	1,600
9500E Twin	CES-9500E-75	75	37.5	62.5	22.5	50	15	2.5	25	32	3.5	125	1.5	0.75	0.75	13 x 54	18 x 40	425	410	1,190
	CES-9500E-90	90	45	75	27	60	18	3	28	36	5.0	159	1.5	0.75	0.75	14 x 65	24 x 40	750	520	1,880
	CES-9500E-120	120	60	100	36	80	24	4	30	39	7.0	195	1.5	0.75	0.75	16 x 65	24 x 40	750	660	2,190
	CES-9500E-150	150	75	125	45	100	30	5	31	40	9.0	243	1.5	1.00	1.00	18 x 65	24 x 40	750	840	2,570
2900E Single	CES-2900E-120	120	60	100	36	80	24	4	47	60	7.0	195	2	1.00	1.00	16 x 65	24 x 40	750	360	1,600
	CES-2900E-150	150	75	125	45	100	30	5	53	69	9.0	249	2	1.00	1.00	18 x 65	24 x 40	750	460	1,830
	CES-2900E-210	210	105	175	63	140	42	7	57	74	12	363	2	1.00	1.00	21 x 62	30 x 48	1200	630	2650
2900E Duplex Parallel	CES-2900E-120-DP	120	60	100	36	80	24	4	94	121	7.0	195	2	1.00	1.00	16 x 65	24 x 40	750	460	1,990
	CES-2900E-150-DP	150	75	125	45	100	30	5	106	137	9.0	249	2	1.00	1.00	18 x 65	24 x 40	750	880	2,610
	CES-2900E-210-DP	210	105	175	63	140	42	7	114	148	12.0	363	2	1.00	1.00	21 x 62	30 x 48	1,200	1,210	3,690

UNPACKING AND INSPECTION

Your Pentair Everpure water softener should arrive on one or more shipping skids. Locate your specific model in the table below. Verify that the specific quantities of boxes or bags indicated have arrived with the system and are undamaged:

Series	Model	Cartons or Bags of Each Item					
		Control Valve(s) and Accessories	Mineral Tank(s)	Brine Tank	Resin	Gravel	
						Bags	Pounds per Tank
2850E Single	CES-2850E-60	1	1	1	3	2	15
	CES-2850E-90	1	1	1	3	1	25
	CES-2850E-120	1	1	1	4	2	35
9500E Twin	CES-9500E-60	1	2	1	5	4	15
	CES-9500E-90	1	2	1	6	2	25
	CES-9500E-120	1	2	1	8	4	35
	CES-9500E-150	1	2	1	10	4	50
2900E Single	CES-2900E-120	1	1	1	4	2	35
	CES-2900E-150	1	1	1	5	2	50
	CES-2900E-210	1	1	1	7	4	80
2900E Duplex Parallel	CES-2900E-120-DP	2	2	1	8	4	35
	CES-2900E-150-DP	2	2	1	10	4	50
	CES-2900E-210-DP	2	2	1	14	8	80

INSTALLATION

MINERAL TANK and CONTROL VALVE

1. Refer to the general arrangement drawings for typical installation examples. The installation area should be reasonably level, smooth, and capable of supporting the operating weight of the system, including salt. See specification table on page 2 for operating weights. All systems include up to four (4) mineral tanks and up to four (4) brine tanks. When determining the best location, consider ease of access for:
 - a. Control valve adjustments and service
 - b. Replenishing the brine tank with salt
2. Position the mineral tank(s) in the desired location.
3. **This step is optional but is strongly recommended for larger systems, so minimal mineral tank movement will be required after filling the mineral tank with media.** Lubricate the O-rings on the base of the control valve (or second tank adaptor) with a silicone based lubricant. Ensure that your silicone based lubricant is NSF approved. While centering distributor tube into the center port on the control valve (or second tank adaptor) base, carefully engage the threads on the control valve (or second tank adaptor) with threads on the mineral tank. Screw control valve (or second tank adaptor) tight. Adjust (rotate) mineral tank so control valve (or second tank adaptor) faces the desired direction. Without moving the mineral tank, remove the control valve (or second tank adaptor).

IMPORTANT: Inspect distributor assembly for damage or missing parts. Some models have a single point strainer, whereas other models have a hub and lateral design. Inspect both types prior to loading media. Ensure the laterals are secure

4. Cover end of distributor tube with tape, plastic bag, etc. This prevents media from entering distributor tube.
5. Positioning the distributor assembly in the tank and verify the distributor tube height using the appropriate illustration below.

IMPORTANT: 2850E and 9500E Series only – distributor tube should be flush with tank top, or slightly below. See example below.

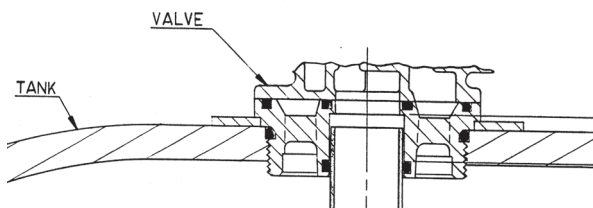

IMPORTANT: 2900 Series only - Distributor tube should be 0.25" to 0.75" (6.35 mm to 19.05 mm) below top of tank. See example below.

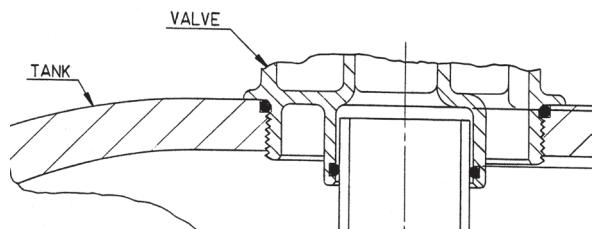

6. **Add water to mineral tank. Fill tank at least 12" (304.8 mm) above distributor slots and/or lateral arms to prevent damage to distributor assembly when adding media.**
7. Add gravel. See table on page 2 for quantities based on model. DO NOT allow gravel to reposition the distributor assembly. Check distributor pipe elevation – do not allow it to rise above the specified level. Rock tank gently to level gravel if required.

⚠ WARNING Gravel dust can be hazardous. Wear suitable dust protection equipment. Wet bags to minimize dust.
8. Add resin. Use water to help "fluidize" resin and speed-up filling process. Resin does not require leveling.
9. Rinse top of mineral tank to remove resin from mineral tank opening area and distributor tube.
10. Remove tape or bag from end of distributor tube.
11. Lubricate O-rings on base of control valve with an NSF-approved silicone based lubricant.
12. Some models include a top collector that attaches to the base of control valve. A raised edge on the top collector engages a groove that is machined into the base of the control valve body. If one has been provided, install it now. See example.



13. Attach control valve to mineral tank.
 - a. Position upper collector and/or control valve center port (distributor tube pilot) over distributor tube, and engage. Rotate control valve clock-wise while engaging threads. When tightened sufficiently, gap between control valve base and mineral tank should be 1/16" (1.59 mm) or less. Follow these same steps for the second tank adaptor – 9500E Series only

PIPING

14. Refer to the general arrangement drawings (pages 12-15) for the location of inlet, outlet, drain and brine line connections.
15. At a minimum, the following plumbing components will be required (not supplied unless noted):
 - a. Inlet and outlet sample valves (optional).
 - b. Unions – control inlet and outlet – (optional, but highly recommended).
 - c. Pipe and fittings – Typically copper for the inlet, outlet, bypass, and PVC for the drain line.

⚠ WARNING Protect control valve, meter body and plastic components from excessive heat. When sweating copper fittings, pre-sweat the piping/fittings prior to connecting them to the system.
16. 2850E, 9500E, 2900E and 2900E models only – Attach meter body directly to control valve outlet. Connect the meter cable to the meter and control valve. The arrow on the meter should point away from the control valve.
17. Install piping, valves, unions and other plumbing components to control valve(s).
 - a. 2900E-DP model only - Use identical lengths of piping and fitting quantities to balance flow/pressure drop through both mineral tanks.

INSTALLATION continued

- Close all valves. Open bypass valve only. Pressurize plumbing system and check for leaks. Flush plumbing to remove foreign material (solder, copper shavings, etc.).

DRAIN LINE

⚠ WARNING 2850E, 9500E and 2900E models require the installation of an external DLFC (drain line flow control) device. This item can be found in the carton with the control valve. The DLFC has an arrow on it. The arrow points away from the control valve when installed. Apply PTFE plumber's tape to male pipe threads and attach DLFC to control valve drain port.

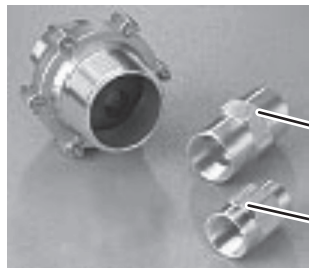

9500E (150),
2900E and
2900E-DP

9500E (75, 90, 120)
and 2850E series

- Keep all remaining valves closed until instructed to open them

NOTE: Refer to the drawing for your model in the back of this manual for an image of the drain line connections.

- Use rigid piping, such as PVC, for the drain piping.
- The maximum vertical lift from the control drain port is 10 feet.
- When excessively long horizontal runs are required, up-size the drain piping as required.
- Adhere to local and national plumbing codes. In all cases, **DO NOT** connect the end of the drain piping directly to the sewer/drain. Provide an air-gap and vacuum break so the system is protected from cross contamination and vacuum.

BRINE TANK

- Position the brine tank in the desired location. It should be placed on a flat surface, free of debris that could cut or puncture the bottom.

NOTE: Refer to the drawing for your model in the back of this manual for an image of the brine line connections.

- Insert a brass tube support into one end of the brine line. Connect this to the safety device in the brine well. Tighten the nut securely.

- Route the brine line to the control valve(s). Trim to length as necessary.
- Insert a brass tube support into the open end of the brine line. Connect this to the brine valve on the control valve. Tighten the nut securely.
- Fill the brine tank with water until the water level is 5-6" (127 - 152 mm) deep. Do not add salt until instructed to do so.

BACKWASH and BRINE LINE CONNECTIONS

System	Backwash Connection Size & Type	Minimum Backwash Line I.D.	Brine Line Connection	Brine Refill Rate (GPM)
2850E Series - 75, 90, 120 9500E Series - 75, 90, 120	3/4" Female NPT	3/4"	3/8" Compression	1.0
2900E Series - 120 2900E-DP Series - 120-DP	1" Female NPT	1"	3/8" Compression	1.0
9500E Series - 150 2900E Series - 150, 210 2900E-DP Series - 150-DP, 210-DP	1" Female NPT	1"	1/2" Compression	2.0

ELECTRICAL

2850E, 9500E, 2900E Models only

See Figure 1 and Figure 2 on pages 5 and 6.

1. Remove screw adjacent to the open rectangular area on the control valve.
2. Open control cover. Pull upper left of valve control to swing open.
3. Remove screw adjacent to the open rectangular area on the meter cover (dome).
4. Insert meter probe on meter cable into rectangular opening. Secure with screw.
5. Remove control cover.
6. Attach cord grip to backplate. Route meter cable through cord grip and connect to P5.
7. Connect the provided 3-wire power cord with power supply to an un-switched wall outlet.
8. Attach cord grip to backplate. Route power cable through cord grip and connect to P14.
9. Connect power cable to power supply connected to wall outlet. The control valve is now powered and may advance to the service position.
10. Reattach cover. Go to the "Control Adjustments" section.

9500E Model only- Connecting Meter cable

1. Remove screw adjacent to the open rectangular area on the meter cover (dome).
2. Insert meter probe on meter cable into rectangular opening. Secure with screw.
3. Remove control cover.
4. Attach cord grip to backplate. Route meter cable through cord grip and connect to P1. Reattach cover
5. Connect the provided 3-wire power cord to an un-switched wall outlet. The control valve is now powered and may advance to the service position. Go to the "Control Adjustments" section

2900E-DP Model only

1. Remove screw adjacent to the open rectangular area on the control cover.
2. Open control cover. Pull upper left of valve control to swing open.
3. See Figure 1 and Figure 2 on pages 5 and 6. for the following steps. Remove screw adjacent to the open rectangular area on the meter cover (dome).
4. Insert meter probe on meter cable into rectangular opening. Secure with screw.
5. Remove control cover.
6. Attach cord grip to backplate. Route meter cable through cord grip and connect to P5.
7. NETWORK/COMMUNICATION CABLES AND CONNECTIONS: Use a shielded CAT5 Network/Communication cable. Connect the network/communication cable first before programming. Cable length between timers/units should not exceed 25 feet.
8. Connect each unit in series (do not form a loop) together from one communication port to the next communication port. It does not matter which one goes to the next one.
9. Attach cord grip to backplate. Route CAT 5 cable through cord grip and connect to P3 on circuit board.
10. Install network cable (CAT 5 cable) between circuit boards in P1 and/or P3. Make sure to route CAT 5 cable through cord grip.
11. Repeat steps 1 through 10 on the other control(s).
12. Connect the provided 3-wire power cord with power supply to an un-switched wall outlet. Attach cord grip to backplate. Route power cable through cord grip and connect to P14. Connect power cable to power supply connected to wall outlet. Repeat process for all control valves. The control valve is now powered and may advance to the service position. Reattach cover. Go to the "Control Adjustments" section.

POWER SUPPLY , METER CABLE & CAT5 CONNECTIONS

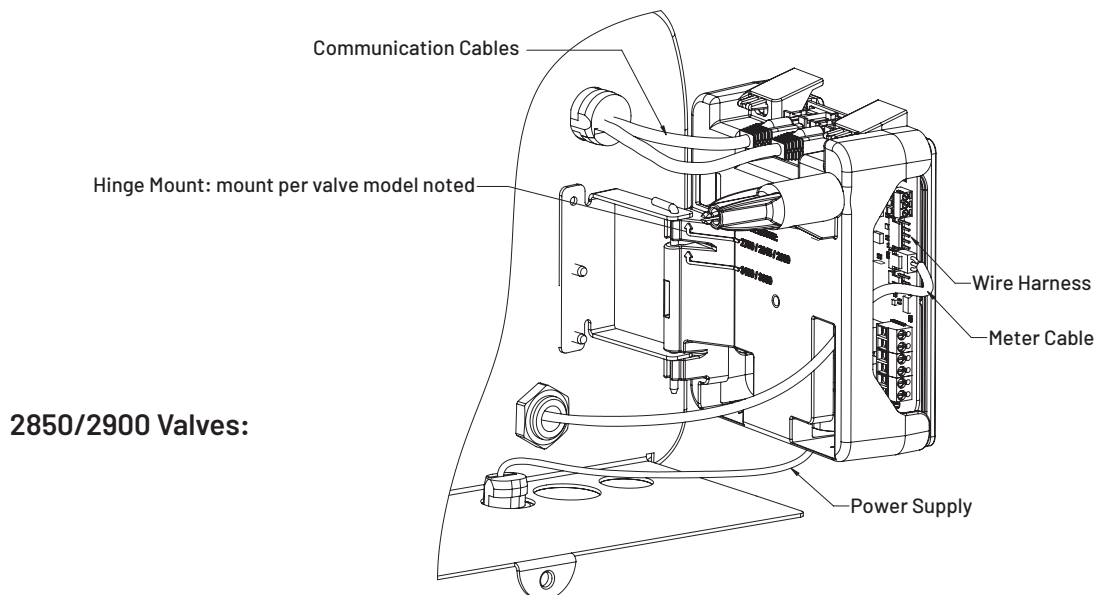

Figure 1

NXT2 WIRING DIAGRAM

*WIRING DIAGRAMS ARE REFERENCE ONLY. ALL WIRING SHOULD BE DONE BY A CERTIFIED ELECTRICIAN AND MEET ALL ELECTRICAL CODES.

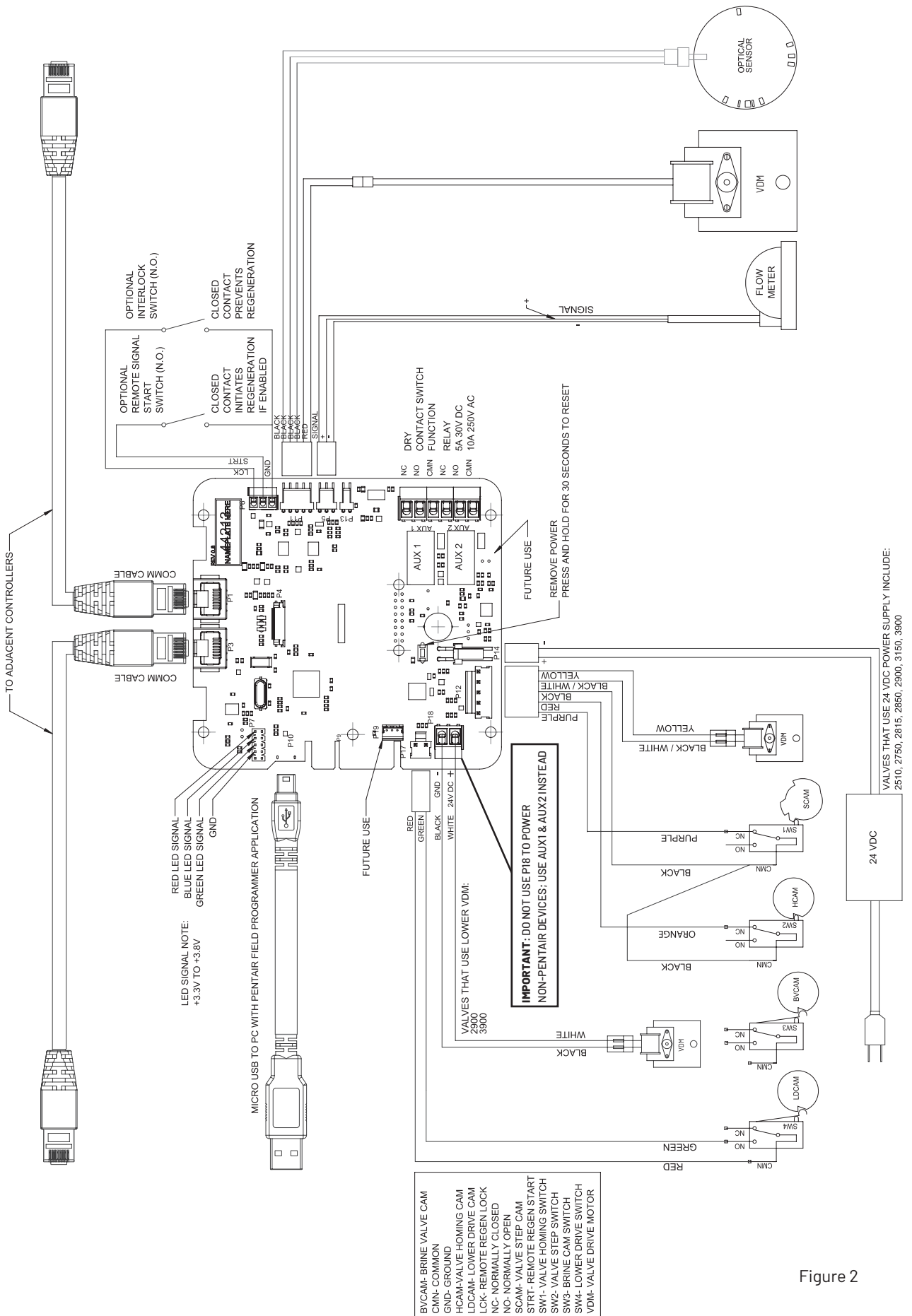

Figure 2

CONTROL ADJUSTMENTS

DETERMINING CAPACITY

Refer to the specification table (page 2) for exchange capacity of each model based on salt dosage.

9500E Model only – The operational mode for this group is metered immediate. In this case, “reserve capacity” is not required.

2900E-DP Model only – The operational mode for this series can vary based on the application. In most cases, the system will operate in meter immediate mode, (system 14), so the regeneration occurs as needed, on only one tank at a time.

2850E and 2900E Models only – The operational mode for all single softeners is system 4 - meter delayed. The unit should be programmed to regenerate at an off-peak time period, such as 2:00 AM. Since this type of system only examines the need to regenerate once every 24 hours, a “reserve capacity” is automatically calculated. The NXT2 controller automatically calculates the reserve capacity and adjusts based on daily usage.

PROGRAMMING

2850E, 2900E and 2900E-DP Models only

Refer to the “3200NXT2 Timer Service Manual” and associated inserts for detailed programming information. A table has been provided on page 9 to assist with programming specific time intervals based on model and system capacity.

NOTE: 2900E-DP Model only –

The programming of each control varies slightly. One control is programmed as the “LEAD” and the other as the “LAG”.

9500E Models only: See pages 9-10. Master Programming Mode

2850E, 2900E and 2900E-DP Models only

1. Press and hold the Left and Down buttons simultaneously for three (3) seconds to enter Master Programming mode.
2. To navigate, press the Extra Cycle button to advance to the next value. Press the Left button to retreat to the previous value.
3. Where applicable, use the Down and Up buttons to adjust a value as desired. When entering data into text fields (such as Assistance Name) or numerical fields (such as Hardness), press the Extra Cycle button to advance to the next character/digit and press the Left button to retreat to the previous character/digit. Proceed through all available characters/digits to advance to the next value.
4. To reset/clear a value (such as Assistance Name), while on the value, press and hold the Down and Up buttons simultaneously for 5 seconds.
5. To exit Master Programming Mode, progress through all available values or after 5 minutes of inactivity the timer will exit automatically. To exit master programming without saving changes, press the Left button until you return to the service screen.
6. Depending on the current controller programming, certain values may not be able to be viewed or set.
7. The timer will display local information, not system information.
8. In the event of a regeneration occurring while displaying master programming, the regeneration step and time remaining will be displayed. When regeneration has been completed, the display will return to the main screen.

NOTE: Refer to page 9 of the “Pentair Fleck NXT2 Timer Service Manual” for more detailed information

WITH SOFTENER VALVE CONTROL SETTINGS

The following table includes the recommended time durations for each regeneration step. These values are based on a typical application. Under certain conditions, these values may require some adjustment. Refer to the performance specifications table on page 2 to determine the usable capacity of the system, based on salt dosage. A detailed description of the “Brine Rinse” and “Brine Tank Refill” time settings has been outlined below:

Min. – Minimum system capacity – based on 6 lbs (2.72 kg) of salt per Ft³ (0.028 M³) of resin.

Med. – Medium system capacity – based on 9 lbs (4.1 kg) of salt per Ft³ (0.028 M³) of resin.

Max. – Maximum system capacity – based on 15 lbs (6.8 kg) of salt per Ft³ (0.028 M³) of resin.

PROGRAMMING MODE continued

MASTER PROGRAMMING

2850E, 2900E, and 2900E-DP models only

Series	Model	System Setting		Trip Point 1			Trip Point 2			Trip Point 3			Valve	Regen Flow	Regen. Type	Capacity	Reserve	Remote Regeneration	Remote Signal Duration	Day Override/Time-Drive
		# Tanks	Trip Point	Service Duration	Standby Duration	Trip Point	Service Duration	Standby Duration	Trip Point	Service Duration	Standby Duration									
2850E Single	CES-2850E-75	4	1	*	*	*	*	*	*	*	*	2850	Downflow	Softener Meter Delayed	Ref. Spec	Variable	OFF	N/A	14 D	
	CES-2850E-90	4	1	*	*	*	*	*	*	*	*	2850	Downflow	Softener Meter Delayed	Ref. Spec	Variable	OFF	N/A	14 D	
	CES-2850E-120	4	1	*	*	*	*	*	*	*	*	2850	Downflow	Softener Meter Delayed	Ref. Spec	Variable	OFF	N/A	14 D	
2900E Single	CES-2900E-120	4	1	*	*	*	*	*	*	*	*	2900	Downflow	Softener Meter Delayed	Ref. Spec	Variable	OFF	N/A	14 D	
	CES-2900E-150	4	1	*	*	*	*	*	*	*	*	2900	Downflow	Softener Meter Delayed	Ref. Spec	Variable	OFF	N/A	14 D	
	CES-2900E-210	4	1	*	*	*	*	*	*	*	*	2900	Downflow	Softener Meter Delayed	Ref. Spec	Variable	OFF	N/A	14 D	
2900E Duplex Parallel	CES-2900E-120-DP	14	2	47	5	300	*	*	*	*	*	2900	Downflow	Softener Meter Immediate	Ref. Spec	Variable	OFF	N/A	14 D	
	CES-2900E-150-DP	14	2	53	5	300	*	*	*	*	*	2900	Downflow	Softener Meter Immediate	Ref. Spec	Variable	OFF	N/A	14 D	
	CES-2900E-210-DP	14	2	57	5	300	*	*	*	*	*	2900	Downflow	Softener Meter Immediate	Ref. Spec	Variable	OFF	N/A	14 D	

Chart continued below.

Series	Model	Regen. Time	Lock Window #1	Regeneration Cycle Time - Minutes										Pause	Meter Type	Continuous Flow Detect Meter Type	Auxiliary 1 Meter Type	Auxiliary 2 Meter Type	Push Setting Meter Type	Save As Non-Factory Meter Type	Lock Settings Meter Type, Enter code:
				Cycle #1 Backwash	Cycle #2			Cycle #3 Rapid Rinse	Cycle #4												
					Brine Rinse (Draw)				Brine Tank Refill												
					Min.	Med.	Max.		Min.	Med.	Max.										
2850E Single	CES-2850E-75	0200	OFF	10	40	50	60	10	5	8	13	0	1.5" P	OFF	OFF	OFF	OFF	ON	1201		
	CES-2850E-90	0200	OFF	10	40	50	60	10	6	9	15	0	1.5" P	OFF	OFF	OFF	OFF	ON	1201		
	CES-2850E-120	0200	OFF	10	40	50	60	10	8	12	20	0	1.5" P	OFF	OFF	OFF	OFF	ON	1201		
2900E Single	CES-2900E-120	0200	OFF	10	40	50	60	10	8	12	20	0	2.0" P	OFF	OFF	OFF	OFF	ON	1201		
	CES-2900E-150	0200	OFF	10	40	50	60	10	5	8	13	0	2.0" P	OFF	OFF	OFF	OFF	ON	1201		
	CES-2900E-210	0200	OFF	10	40	50	60	10	7	11	18	0	2.0" P	OFF	OFF	OFF	OFF	ON	1201		
2900E Duplex Parallel	CES-2900E-120-DP	0200	OFF	10	40	50	60	10	8	12	20	0	2.0" P	OFF	OFF	OFF	ON	ON	1201		
	CES-2900E-150-DP	0200	OFF	10	40	50	60	10	8	13	21	0	2.0" P	OFF	OFF	OFF	ON	ON	1201		
	CES-2900E-210-DP	0200	OFF	10	40	50	60	10	7	11	18	0	2.0" P	OFF	OFF	OFF	ON	ON	1201		

*This step does not apply. The programming proceeds to the next step.

PROGRAMMING MODE continued

MASTER PROGRAMMING 9500E Series only

When the Master Programming Mode is entered, all available option setting displays may be viewed and set as needed. Depending on current option settings, some parameters cannot be viewed or set. Setting the Time of Day

1. Press and hold either the Up or Down buttons until the programming icon replaces the service icon and the parameter display reads DO.
2. Adjust the displayed time with the Up and Down buttons.
3. When the desired time is set, press the Extra Cycle button to resume normal operation. The unit will also return to normal operation after 5 seconds if no buttons are pressed

Entering Master Programming Mode

Set the Time Of Day display to 12:01 P.M. Press the Extra Cycle button (to exit Setting Time of Day mode). Then press and hold the Up and Down buttons together until the programming icon replaces the service icon and the Display Format screen appears.

Exiting Master Programming Mode

Press the Extra Cycle button to accept the displayed settings and cycle to the next parameter. Press the Extra Cycle button at the last parameter to save all settings and return to normal operation. The control will automatically disregard any programming changes and return to normal operation if it is left in Master Programming mode for 5 minutes without any keypad input.

NOTE: Refer to page 5 of the "Fleck SXT Timer Service Manual" for more detailed information

9500E SERIES PROGRAMMING

Series	Model	Display Format	Valve Type	Control Type	Number of Tanks	Tank in Service*	Unit Capacity	Feedwater Hardness	Reserve Selection	Safety Factor	Fixed Reserve Capacity	Day Override
9500E Twin	CES-9500E-75	GAL	dF1b	FI	2	U1	Ref. Spec	Enter Water Hardness	rc	0	0	14
	CES-9500E-90	GAL	dF1b	FI	2	U1	Ref. Spec	Enter Water Hardness	rc	0	0	14
	CES-9500E-120	GAL	dF1b	FI	2	U1	Ref. Spec	Enter Water Hardness	rc	0	0	14
	CES-9500E-150	GAL	dF1b	FI	2	U1	Ref. Spec	Enter Water Hardness	rc	0	0	14

Chart continued below.

Series	Model	Regeneration Time	Regeneration Cycle Time - Minutes								Flow Meter Type
			Cycle #1 Backwash (BW)	Cycle #2			Cycle #3			Cycle #4 Rapid Rinse (RR)	
				Brine Draw (BD)			Brine Tank Refill (BF)				
				Min.	Med.	Max.	Min.	Med.	Max.		
9500E Twin	CES-9500E-75	2:00 AM	10	40	50	60	5	8	13	10	P1.5
	CES-9500E-90	2:00 AM	10	40	50	60	6	9	15	10	P1.5
	CES-9500E-120	2:00 AM	10	40	50	60	8	12	20	10	P1.5
	CES-9500E-150	2:00 AM	10	40	50	60	10	15	25	10	P1.5

PROGRAMMING MODE continued

9500E Series only

TANK IN SERVICE* INSTRUCTIONS

If the bottom arrow is pointed down to Tank 1 then program Tank in Service to U1. If the bottom arrow is pointed up to Tank 2 then program Tank in Service to U2.

Start-Up Instructions

Refer to page 11 under **Commissioning: Mineral Tank Fill - Operational Check-Out** for more details on testing brine fill, draw and float test.

1. Slowly open the inlet water valve and allow softener to fill with water.
2. Press and hold "Extra Cycle" button for 5 seconds until the valve begins to cycle to BW, allow softener to backwash until air is expelled from softener and water is running clear and smooth down the drain.
3. Advance control valve to BD Brine Draw by pressing the "Extra Cycle" button.
4. Advance control valve to RR Rapid Rinse by pressing the "Extra Cycle" button.
5. Advance control valve to BF Brine Fill by pressing the "Extra Cycle" button. Allow softener to fill brine tank to the top of the air check. Once the water level is above the air check press the "Extra Cycle" button to return the valve back to service.
6. Repeat steps 2-5 for the second tank but for step 5 you would allow the softener to do a complete brine fill cycle and allow the unit to return to service on its own.
7. Open outlet bypass valve.

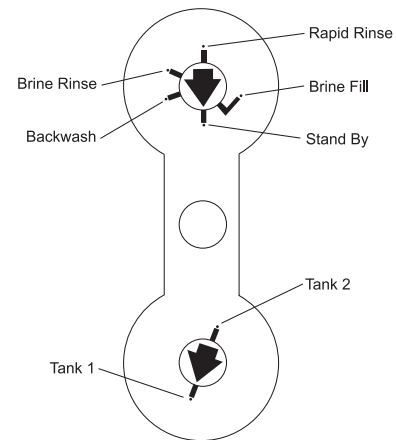

Control Valve Position Indicators

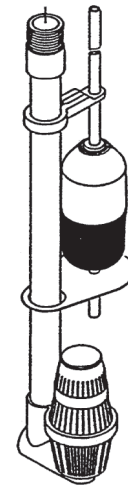

Safety Brine Valve

COMMISSIONING

MINERAL TANK FILL – OPERATIONAL CHECK-OUT

1. Manually initiate a regeneration cycle. The control valve will advance to the backwash position. PARTIALLY open the inlet isolation valve to allow water to SLOWLY enter the mineral tank and purge the mineral tank of air.

⚠ WARNING Limit the flow of water into the mineral tank at this time. Opening the inlet isolation valve too far may expand the resin bed too greatly and cause resin loss to drain. Observe the water exiting to drain during this time for the presence of resin. Throttle inlet isolation valve as required.

2. Once the air is purged, open the inlet valve fully and allow water to run to drain for five (5) minutes. Continue to check for the presence of resin during this time. If resin appears, close inlet valve and re-check system.

- a. Manually advance the control valve to the fast rinse position. The flow to drain will be the same as in backwash. Allow the unit to remain in this mode for two (2) minutes. Then advance valve to next step – brine refill.

⚠ WARNING Observe the water exiting to drain during this time for the presence of resin. If resin loss is observed, close inlet isolation valve. Contact technical service –1.800.942.1153.

- b. Once in brine refill, no flow will be present at the drain. Observe the water level in the brine tank – the level will be ascending.
- c. Raise brine float, ensure there are no leaks and make sure that the water flow into the brine tank has stopped. Once no leaks are found, release the brine float.
- d. Fill brine tank with salt.

3. Manually advance the control valve to the brine rinse position. The flow to drain will be about 1/3 the flow in backwash. Observe the water level in the brine tank – the level should descend, and within a few minutes, the air-check should seat. A distinct change will be heard in the “tone” of the control valve.

⚠ WARNING Observe the water exiting to drain during this time for the presence of resin. If resin loss is observed, close inlet isolation valve. Contact technical service – 1.800.942.1153.

Manually advance the control valve to the fast rinse position. **This process can also be used to test the water hardness reduction of each individual tank in a system.** The flow to drain will be the same as in backwash. Allow the unit to remain in this mode until it automatically advances to the next step – brine refill.

⚠ WARNING Observe the water exiting to drain during this time for the presence of resin. If resin loss is observed, close inlet isolation valve. Contact technical service –1.800.942.1153.

4. Once in brine refill, no flow will be present at the drain. Observe the water level in the brine tank – the level will be ascending.
5. **2850E and 2900E Models only** – Allow the control to remain in this step for the programmed time. The control valve will advance automatically to service.

9500E Series only see page 10 for additional instructions to bring softener into service.

2900E-DP Model only – Advance the control valve to the service position. Repeat steps 1-5 on each additional mineral tank/ control valve.

NOTE: The next steps require placing the system “online”. Failure to follow these steps closely could interrupt the water supply to the downstream equipment.

VERIFY FLOW METER CONTROL

1. Open manual outlet isolation valve.
2. Close bypass valve.
3. Demand water from a downstream device, or piece of equipment.

Observe the flow rate reading on the display unit of the control valve. If possible, measure the flow and compare this flow rate to what’s displayed. If the flows are noticeably different, verify the controller settings – specifically the “Flow Meter Size” setting.

TESTING FOR SOFT WATER

2850E, 9500E and 2900E Models only –

1. Open a downstream plumbing fixture or soft water sample port and allow water to run for a few minutes.
2. Collect a sample and test for the presence of hardness – should be <3 GPG (51.3 mg/L). If hardness is higher, re-check after several minutes. If a hardness level of <3 GPG (51.3 mg/L) cannot be attained, re-check bypass valves (fully closed) or refer to control valve manual troubleshooting section for further assistance.
3. Close downstream plumbing fixture or soft water sample port.
4. System is now in service.

2900E-DP Model only –

1. Refer to step 3 under Commissioning: Mineral Tank Fill – Operational Check-Out to test for soft water during rapid rinse.

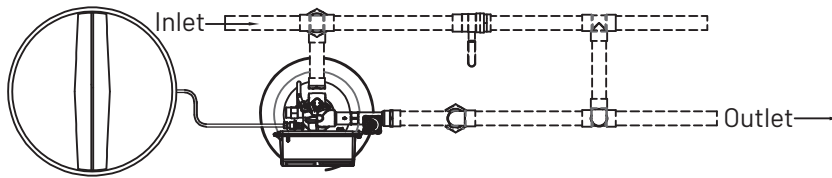

TOP VIEW

External Plumbing is not Included

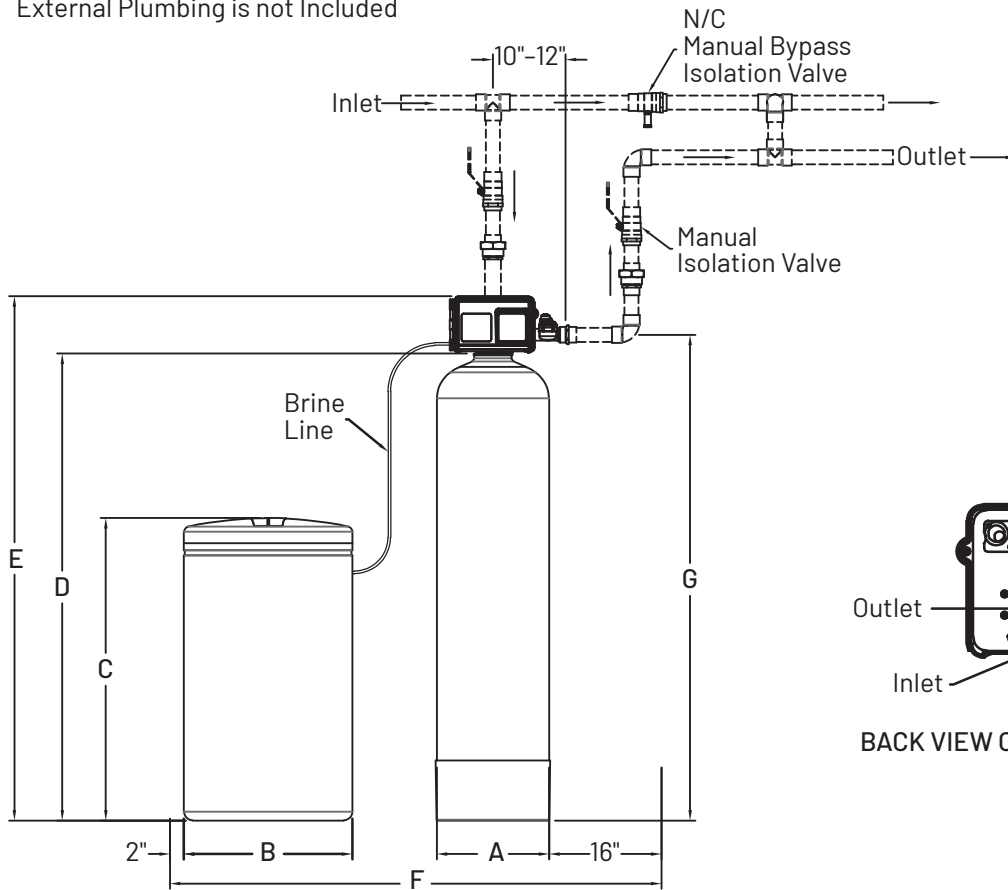

FRONT VIEW

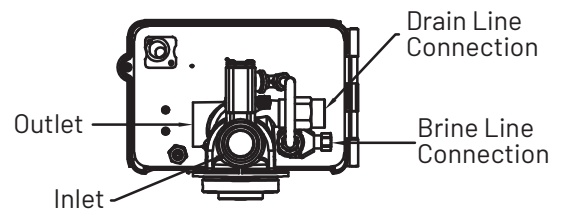

BACK VIEW OF 2850 CONTROL VALVE

MODEL	Dimensions (inches)						
	A	B	C	D	E	F	G
CES-2850E-60	13	19	42	54	64	54 MIN - 230*	56
CES-2850E-90	14	24	41	65	74	60 MIN - 236*	66
CES-2850E-120	16	24	41	65	74	62 MIN - 238*	66

*Brine tank to be no more than 15 linear feet from the furthest softener tank.

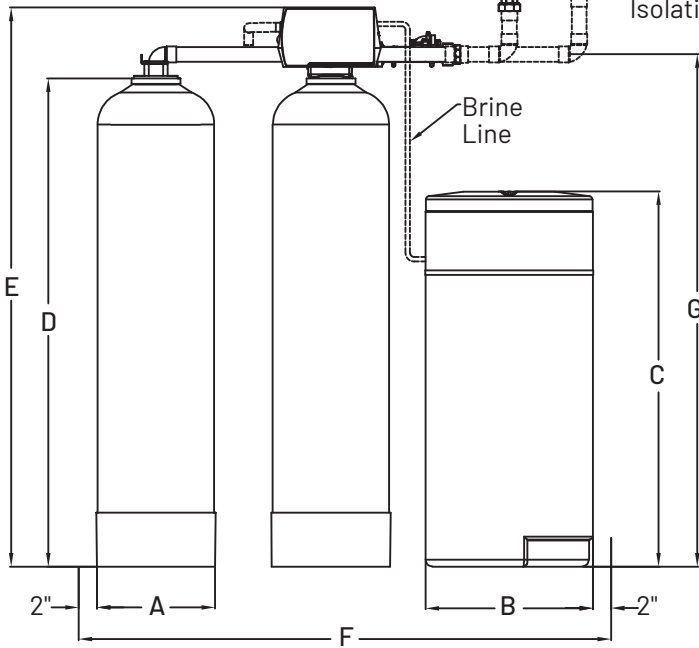
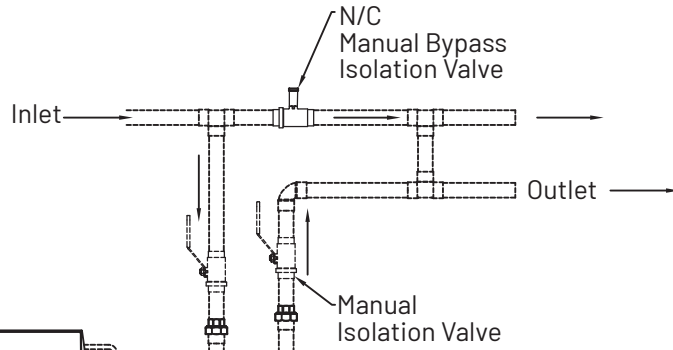
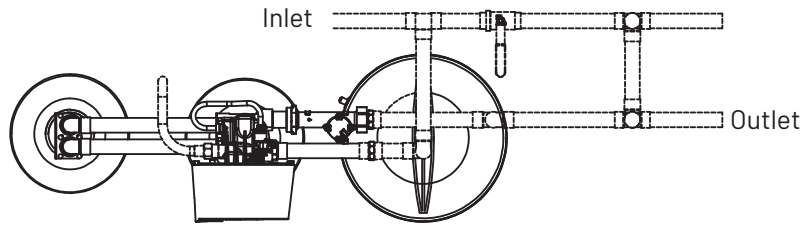

FRONT VIEW

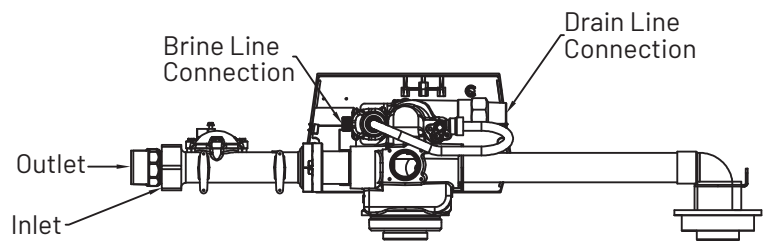

BACK VIEW OF 9500 CONTROL VALVE

MODEL	Dimensions (inches)						
	A	B	C	D	E	F	G
CES-9500E-75	13	19	42	54	64	60 MIN - 236*	57
CES-9500E-90	14	24	41	65	74	66 MIN - 242*	67
CES-9500E-120	16	24	41	65	74	68 MIN - 244*	67
CES-9500E-150	19	24	41	67	77	75 MIN - 251*	70

*Brine tank to be no more than 15 linear feet from the furthest softener tank.

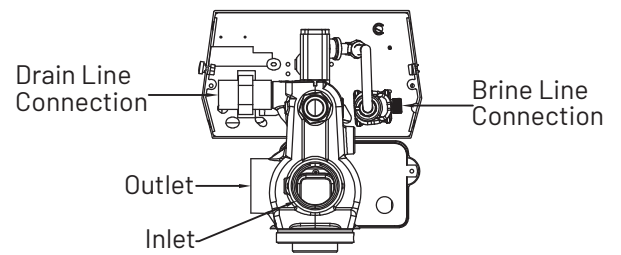
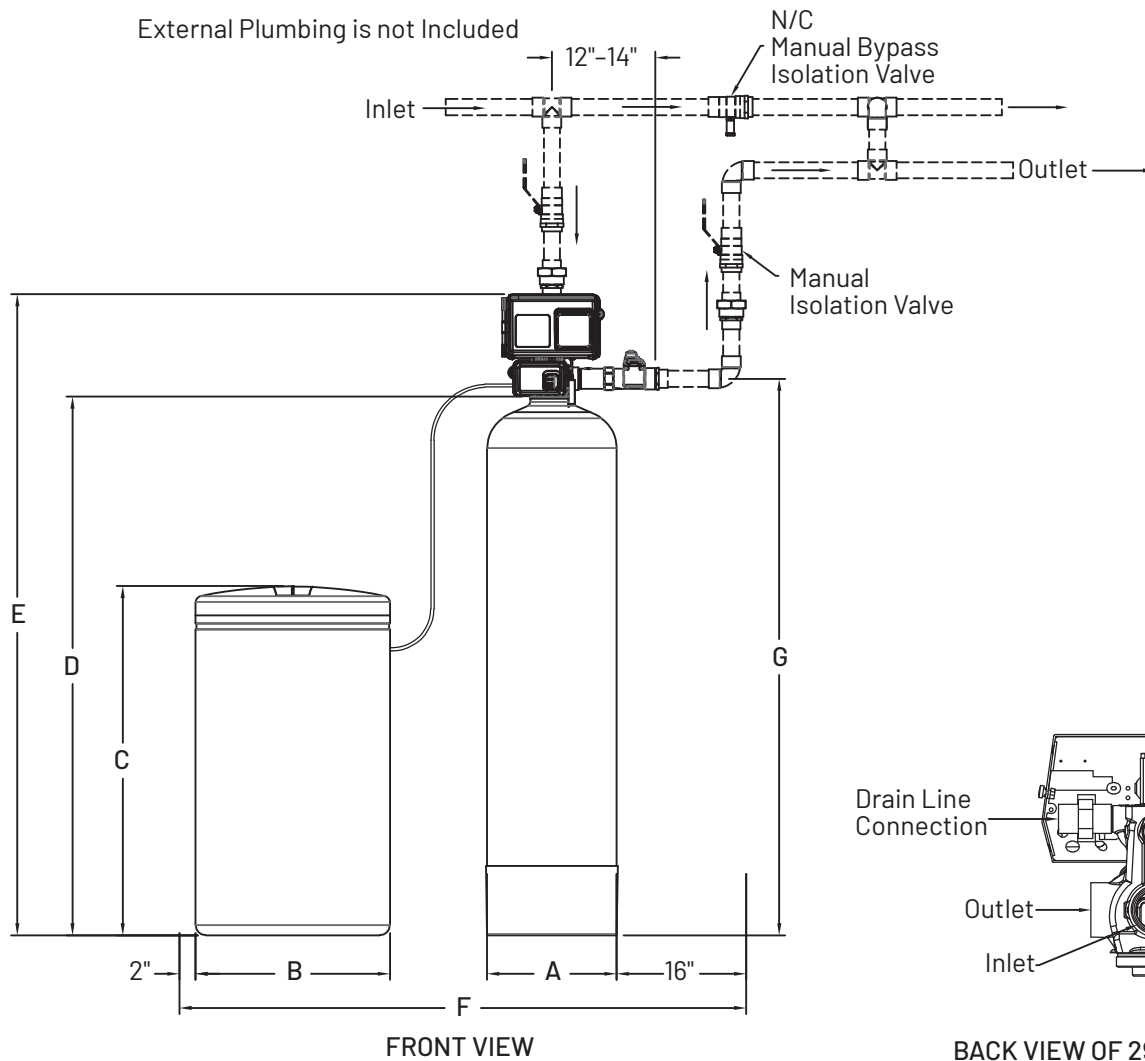
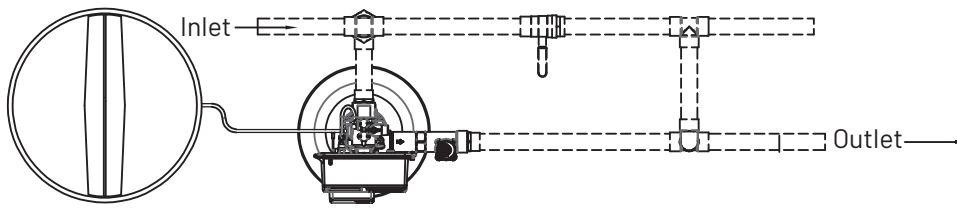

MODEL	Dimensions (inches)						
	A	B	C	D	E	F	G
CES-2900E-120	16	24	41	65	79	62 MIN - 238*	67
CES-2900E-150	19	24	41	67	82	65 MIN - 241*	69
CES-2900E-210	21	30	48	67	82	73 MIN - 249*	69

*Brine tank to be no more than 15 linear feet from the furthest softener tank.

2900E-DP SERIES DRAWING

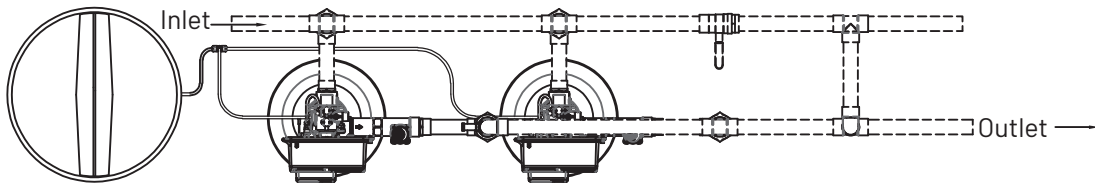

TOP VIEW

External Plumbing is not Included

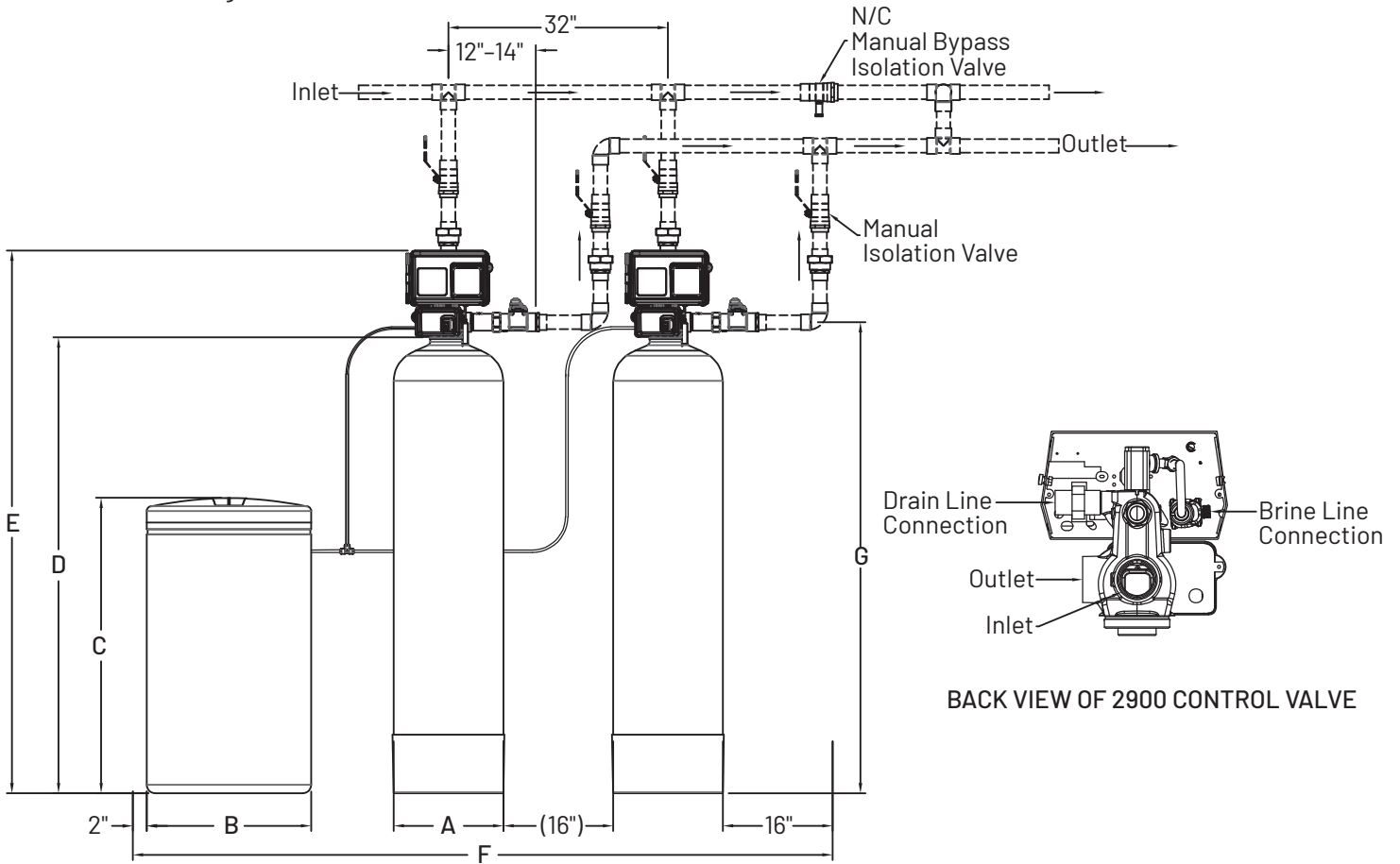

FRONT VIEW

BACK VIEW OF 2900 CONTROL VALVE

MODEL	Dimensions (inches)						
	A	B	C	D	E	F	G
CES-2900E-120-DP	16	24	41	65	80	94 MIN - 270*	68
CES-2900E-150-DP	18	24	41	65	80	98 MIN - 278*	68
CES-2900E-210-DP	21	30	48	62	77	110 MIN - 290*	65

*Brine tank to be no more than 15 linear feet from the furthest softener tank.



For Pentair Everpure Product Warranties visit:
<http://pentair.com/assets/foodservice-warranty>

To receive a free copy of the warranty terms, please email or call your Pentair representative using the information provided below.

United States | 1040 Muirfield Drive | Hanover Park, IL 60133 | 800.942.1153 (US Only) 630.307.3000 Main | cseverpure@pentair.com | foodservice.pentair.com
Australia | 1-21 Monash Drive | Dandenong South, Vic 3175 | Australia | 011.1300 576 190 Tel | au.everpure@pentair.com
China | 21F Cloud 9 Plaza, NO 1118 | Shanghai, 200052 | China | 86.21.3211.4588 Tel | china.water@pentair.com
India | Boulevard, B-9/A, 7th Floor - Tower B Sector 62 | Noida - 201301 | 91.120.419.9444 Tel | indiacustomer@pentair.com
Europe | Pentair Water Belgium BV | Industriepark Wolfstee, Toekomstlaan 30, B-2200 Herentals | Belgium | +32.(0).14.283.504 Tel | sales@everpure-europe.com
Southeast Asia | 390 Havelock Road, | #04-01 King's Centre | Singapore 169662 | 65.6768.5800 Tel | cseverpure@pentair.com

All indicated Pentair trademarks and logos are property of Pentair. Third party registered and unregistered trademarks and logos are the property of their respective owners

©2025 Pentair. All rights reserved.

EV312171 Rev F 0C25